

## Smart-UPS RT (VA):

1000, 1500, 2000, 2200, 2400, 3000  
5000, 6000, 7500, 8000, 10000

### STEP 1:

Connect the UPS's Internal Batteries  
(Figure 1):

**NOTE:** Procedures 1-3 pertain to 3KVA models and higher.  
Procedures A-D pertain to 2KVA models and lower.

#### Procedure for Figure 1: (1, 2, 3)

- 1.1 Remove the Front Bezel – the reverse procedure of 3
- 1.2 Free the Brown Battery Connectors and press them into the Brown Plug at the top of the battery housing 1
- 1.3 A snap will be felt as the connectors partially engage the jacks. A second snap will be felt as the connectors securely seat in the Battery Jacks 2
- 1.4 Replace the Front Bezel and snap it into place 3

#### OR

#### Procedure for Figure 1: (A)

- 1.1 Remove the Battery Compartment Door A
- 1.2 Insert the Battery Connector into the matching connector on the inside of the UPS Battery Compartment B
- 1.3 Replace the Battery Compartment Door C
- 1.4 Replace the Front Bezel and snap it into place D

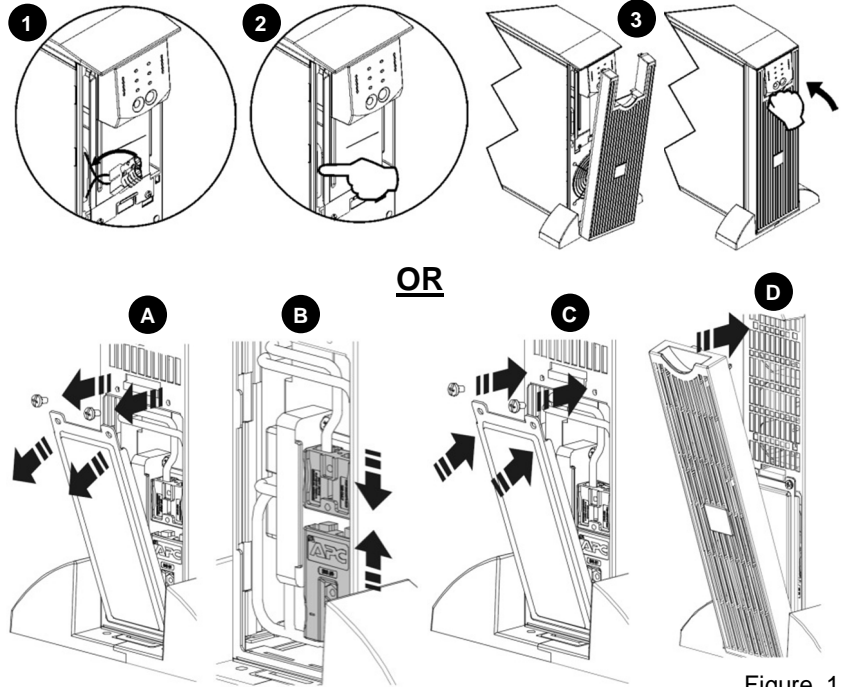

Figure 1

### STEP 2:

Install UPS accessories (Figure 2):

**NOTE:** Ensure the UPS is turned off prior to installing any accessories.  
Some accessories are not provided with the UPS, please contact APC or CBM for the compatible accessories.

- 2.1 Install SmartSlot accessory (if applicable) 1
- 2.2 Install all external Battery Packs (if applicable) 2
- 2.3 Install Step-down transformer (if applicable) 3

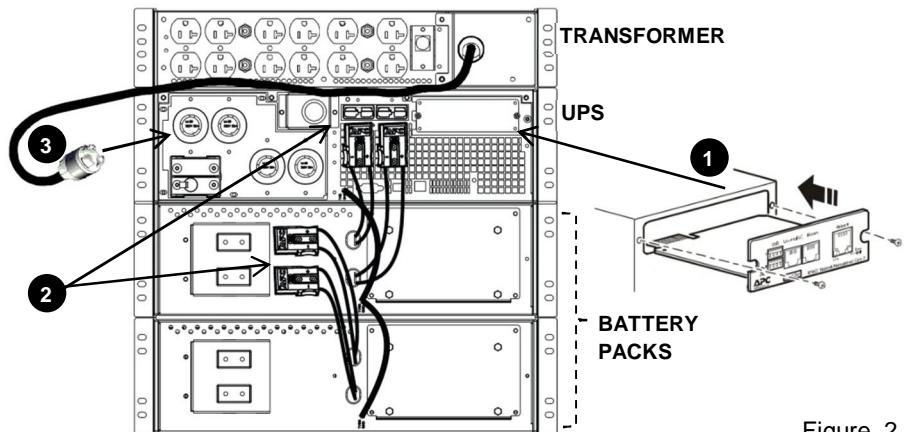

Figure 2

### STEP 3:

Connect equipment & charge UPS (Figure 3):

**NOTE:** Ensure equipment is turned off.  
7.5KVA models and higher require a hard-wired utility supply.

- 3.1 Connect equipment to UPS 1
- 3.2 Connect UPS Power Cord to a two-pole, three-wire, grounded receptacle 2
- 3.3 Set UPS circuit breakers to the 'ON' position (if applicable) 3
- 3.4 Power-up the UPS by pressing the button.
- 3.5 Wait for the Self-Test to complete, then Power-up equipment.
- 3.6 Allow UPS to charge batteries for 24 hours prior to operating on battery or performing additional Self-Test or Calibration tests.

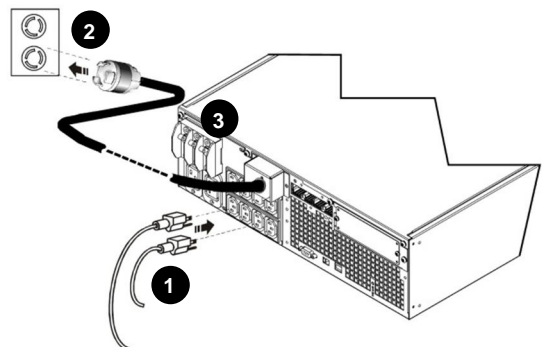

Figure 3

**UPS Front Panel (Figure 4):**

**NOTE:** Symbols & functions may differ on some UPS models.

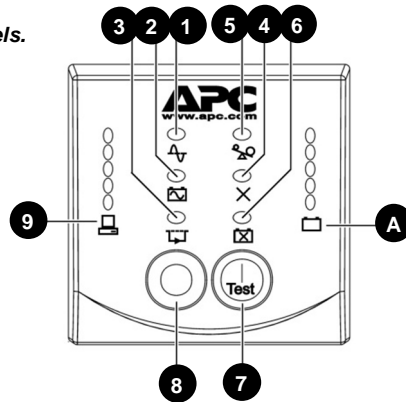

Figure 4



**POWER 'ON' BUTTON** - Button to turn UPS on. If UPS is off, press and hold to cold-start. If UPS on and connected to utility power, press and hold to self-test.



**POWER 'OFF' BUTTON** - Button to turn UPS off.



**ONLINE** - UPS is supplying utility power to the connected equipment. If not lit, the UPS is not turned ON, or is supplying battery power.



**ON BATTERY** - UPS is supplying battery backup power to the connected equipment. UPS will beep four times every 30 seconds.



**REPLACE BATTERY** - UPS fails a self-test, or battery is bad. UPS makes short beeps for a minute. Flashes to indicate the battery is disconnected. UPS will beep every two seconds.



**OVERLOAD** - The power demand from the load has exceeded the capacity of the UPS. A sustained alarm tone is also emitted.



**LOAD CAPACITY** - The load is indicated by the number of sections illuminated, one to five. Each bar represents 20% of the load.



**BATTERY CHARGE** - The battery charge level is indicated by the number of sections illuminated. When all five blocks are illuminated, the UPS is at full charge.



**BYPASS** - Indicates that the UPS is in bypass mode. Utility power is sent directly to connected equipment during bypass mode operation.



**FAULT** - The UPS detects an internal fault.

**UPS Back Panel (Figure 5):**

**NOTE:** Panel layout may differ on some models.

1	Manual Bypass switch
2	Serial UPS monitoring port
3	Chassis ground connection screw (TVSS GND)
4	SmartSlot for optional NMC accessory card
5	Circuit breaker/Overload protection
6	UPS input
7	Outlets
8	EPO connector
9	External Battery Pack connector

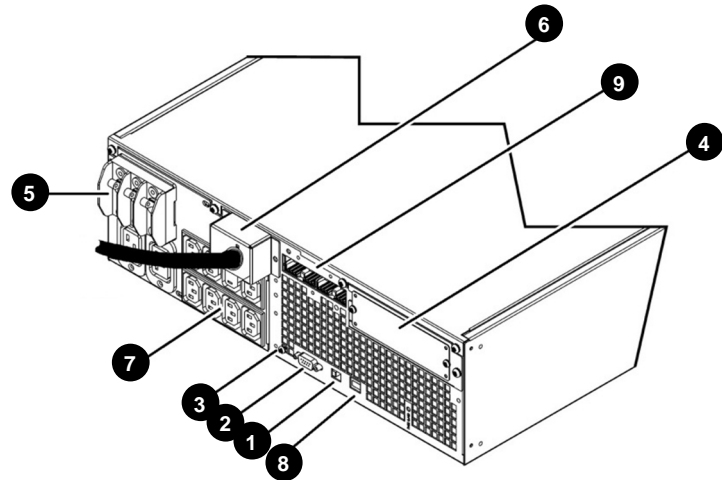

Figure 5

**UPS Troubleshooting:****NOTE: Troubleshooting procedures may differ depending on UPS model.****Problem:****Solution:**

<b>UPS will not turn on</b>	
• Battery not connected properly.	Check that the battery connectors are fully engaged.
• Power "ON" button not pushed.	Press the Power 'ON' button once to power the UPS and the connected equipment.
• UPS not connected to utility power supply.	Check that the power cable from the UPS to the utility power supply is securely connected at both ends.
• Very low or no utility voltage.	Check the utility power supply to the UPS by plugging in a table lamp. If the light is very dim, have the utility voltage checked.
<b>UPS will not turn off</b>	
• Power 'OFF' button not pushed.	Press the Power 'OFF' button once to turn the UPS off.
• Internal UPS fault.	Do not attempt to use the UPS. Unplug the UPS and have it serviced immediately.
<b>UPS beeps occasionally</b>	
• Normal UPS operation when running on battery.	None. The UPS is protecting the connected equipment.
<b>UPS does not provide expected backup time</b>	
• The UPS battery(s) are weak due to a recent outage or battery(s) are near the end of their service life.	Charge the battery(s). Battery modules require recharging after extended outages. They wear faster when put into service often or when operated at elevated temperatures. If the battery(s) are near the end of their service life, consider replacing the battery(s) even if the 'Replace Battery' indicator is not illuminated.
<b>Front panel indicators flash sequentially</b>	
• The UPS has been shut down remotely through software or an optional accessory card.	None. The UPS will restart automatically when utility power returns.
<b>All indicators are off and the UPS is plugged into a wall outlet</b>	
• The UPS is shut down and the battery is discharged from an extended outage.	None. The UPS will return to normal operation when the power is restored and the battery has a sufficient charge.
<b>'Bypass' and 'Overload' indicators illuminate, UPS emits a sustained alarm tone</b>	
• The UPS is overloaded	The connected equipment exceeds the specified "maximum load" of the UPS. The alarm remains on until the overload is removed. Disconnect nonessential equipment from the UPS to eliminate the overload condition.
<b>'Bypass' indicator illuminates</b>	
• The bypass switch has been turned on manually or through an accessory.	If bypass is the chosen mode of operation, ignore the illuminated 'Bypass' indicator. If bypass is not the chosen mode of operation move the bypass switch on the back of the UPS, to the normal position.
<b>'Fault' and 'Overload' indicators illuminate, UPS emits a sustained alarm</b>	
• Test The UPS has ceased sending power to connected equipment.	The connected equipment exceeds the specified "maximum load" of the UPS. Disconnect nonessential equipment from the UPS to eliminate the overload condition. Press the 'OFF' button, then the 'ON' button to restore power to connected equipment.
<b>'Fault' indicator illuminates</b>	
• Internal UPS fault.	Do not attempt to use the UPS. Turn the UPS off and have it serviced immediately.
<b>'Replace Battery' indicator illuminates</b>	
• Replace Battery LED flashes and short beep is emitted every two seconds to indicate the battery is disconnected.	Check that the battery connectors are fully engaged.
• Weak battery.	Allow the battery to recharge for 24 hours. Then, perform a self-test. If the problem persists after recharging, replace the battery.
• Failure of a battery self-test.	The UPS emits short beeps for one minute and the 'Replace Battery' indicator illuminates. The UPS repeats the alarm every five hours. Perform the self-test procedure after the battery has charged for 24 hours to confirm the 'Replace Battery' condition. The alarm stops and the indicator clears if the battery passes the self-test.

UPS Troubleshooting (continued):

**Problem:**

**Solution:**

**UPS operates on battery although normal line voltage exists**

- |   |   |
|---|---|
| <ul style="list-style-type: none"><li>• Very high, low, or distorted line voltage. Inexpensive fuel powered generators can distort the voltage.</li></ul> | Move the UPS to a different outlet on a different circuit. Test the input voltage with the utility voltage display. |
|---|---|

**Diagnostic utility voltage**

- |  |  |
|--|--|
| <ul style="list-style-type: none"><li>• All five LEDs are illuminated.</li></ul> | The line voltage is extremely high and should be checked by an electrician.                                |
| <ul style="list-style-type: none"><li>• There is no LED illumination.</li></ul>  | If the UPS is plugged into a properly functioning utility power outlet, the line voltage is extremely low. |

**'Online' indicator**

- |   |  |
|---|--|
| <ul style="list-style-type: none"><li>• There is no LED illumination.</li></ul> | The UPS is running on battery, or it is not turned on. |
| <ul style="list-style-type: none"><li>• The LED is blinking.</li></ul>          | The UPS is running an internal self-test.              |

For the complete User Manual or comprehensive troubleshooting, please visit the following websites:

APC: <http://www.apc.com> or CBM: <http://www.buyupsonline.com>